

PRODUCT ECOSYSTEM MANUAL



CONTACT US

FAIR Innovation (Suzhou) Robot System Co.,Ltd.

R&D Center : No.209 Zhuyuan Road,New District,Suzhou,Jiangsu,PR.China
Manufacture Base 1 : No.5888 Zunxian Road,New District,Zibo,Shandong,PR.China
Manufacture Base 2 : No.36 Zijin Road,New District,Suzhou,Jiangsu,PR.China

+86 400-811-0929 www.fairino.com sales@fairino.com



Official website



Youtube



Linkedin



Download

FAIRINO

FAIRINO

- » **Modularization**
- » **Quick deployment**
- » **Easy operation**



FAIRINO ROBOT

PRODUCT VISION

产品愿景

Collaborative robots will extend your time and space, liberate complex and inefficient repetition, and let you embrace a wider horizon. In the future, You will see **FAIRINO ROBOTS**.

With its emergence, it not only improves the efficiency of human-machine collaboration, but also speeds up the automation process for more enterprises and frees floor space and lowers the cost of implementing robots for manufacturers.

PRODUCT DISPLAY



FR3 >> FR3-C FR3-WMS FR3-WML

FR3 SERIES

FR5 >> FR5-WML

FR5 SERIES

FR10 FR16 FR20 FR30



FAIRINO FR SERIES

According to different payload and parameter, FAIRINO collaborative robots FR series are divided into the following models:FR3(Optional Mirror Version), FR3-C, FR3-WMS,FR3-WML, FR5, FR5-WML, FR10, FR16, FR20 and FR30. To provide partners&customers with better quality assurance,FAIRINO has obtained a more comprehensive range of certificates through international certification organizations.

Quality Management System: ISO 9001

Product Certification: CR, CE, KCs, NRTL, RoHS 2.0, NSF, SEMI, IP65

ISO Functional Safety Certification: ISO10218, ISO13849, ISO15066

Intelligent human-robot cooperation system solutions

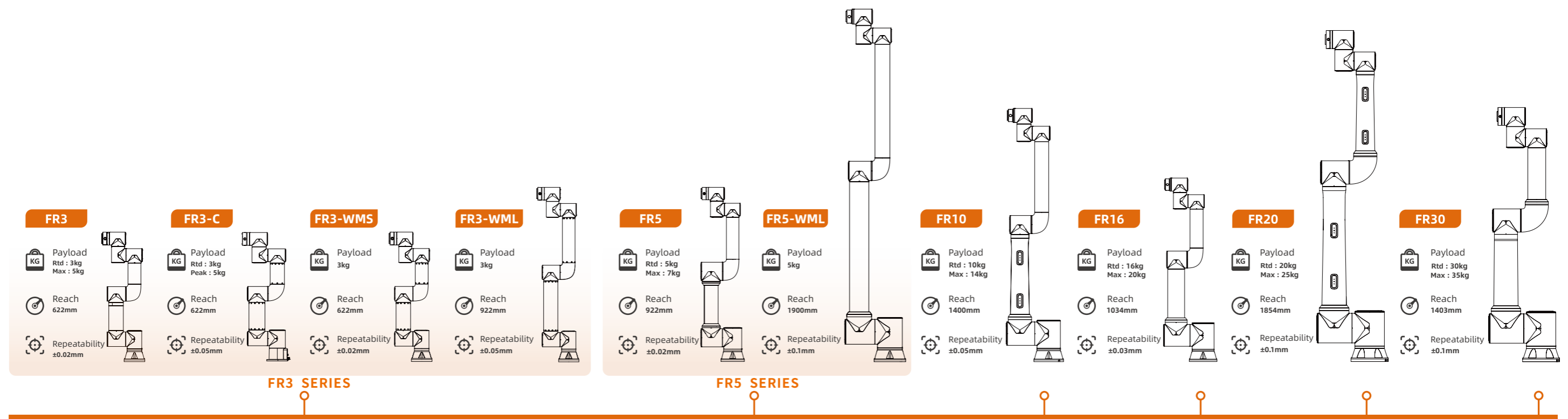

ROBOT ARM TECHNICAL SPECIFICATION

>> FR3 SERIES <<

>> FR5 SERIES <<

	FR3				FR3-C				FR3-WMS		FR3-WML		FR5		FR5-WML		FR10		FR16		FR20		FR30			
Payload	3kg(Max:5kg)				3kg (peak:5kg)				3kg		3kg		5kg (Max:7kg)		5kg		10kg (Max:14kg)		16kg (Max:20kg)		20kg (Max:25kg)		30kg (Max:35kg)			
Reach	622mm				622mm				622mm		922mm		922mm		1900mm		1400mm		1034mm		1854 mm		1403 mm			
Degrees of freedom	6 rotating joints				6 rotating joints				6 rotating joints		6 rotating joints		6 rotating joints		6 rotating joints		6 rotating joints		6 rotating joints		6 rotating joints		6 rotating joints			
HMI	10.1 inch teach pendant or mobile terminal Web App				10.1 inch teach pendant or mobile terminal Web App				10.1 inch teach pendant or mobile terminal Web App		10.1 inch teach pendant or mobile terminal Web App		10.1 inch teach pendant or mobile terminal Web App		10.1 inch teach pendant or mobile terminal Web App		10.1 inch teach pendant or mobile terminal Web App		10.1 inch teach pendant or mobile terminal Web App		10.1 inch teach pendant or mobile terminal Web App		10.1 inch teach pendant or mobile terminal Web App			
Dual arm robotics applications	Mirror versions available to build dual arm robots																									
Pose repeatability per ISO 9283	±0.02mm				±0.05mm				±0.02mm		±0.05mm		±0.02mm		±0.1mm		±0.05mm		±0.03mm		±0.1mm		±0.1mm		±0.1mm	
Axis movement	Working range	Maximum speed	Working range	Maximum speed	Working range	Maximum speed	Working range	Maximum speed	Working range	Maximum speed	Working range	Maximum speed	Working range	Maximum speed	Working range	Maximum speed	Working range	Maximum speed	Working range	Maximum speed	Working range	Maximum speed	Working range	Maximum speed		
Base	±175°	±180°/s	±175°	±150°/s	±175°	±150°/s	±175°	±150°/s	±175°	±180°/s	±175°	±120°/s	±175°	±120°/s	±175°	±120°/s	±175°	±120°/s	±175°	±120°/s	±175°	±120°/s	±175°	±120°/s		
Shoulder	+85° / - 265° (Dual Arm: -85° / + 265°)	±180°/s	+85° / - 265°	±150°/s	+85° / - 265°	±150°/s	+85° / - 265°	±150°/s	+85° / - 265°	±180°/s	+85° / - 265°	±120°/s	+85° / - 265°	±120°/s	+85° / - 265°	±120°/s	+85° / - 265°	±120°/s	+85° / - 265°	±120°/s	+85° / - 265°	±120°/s	+85° / - 265°	±120°/s		
Elbow	±150°	±180°/s	±150°	±150°/s	±150°	±150°/s	±150°	±150°/s	±160°	±180°/s	±170°	±180°/s	±160°	±180°/s	±160°	±180°/s	±160°	±180°/s	±160°	±180°/s	±160°	±180°/s	±160°	±180°/s		
Wrist 1	+85° / - 265° (Dual Arm: -85° / + 265°)	±180°/s	+85° / - 265°	±180°/s	+85° / - 265°	±180°/s	+85° / - 265°	±180°/s	+85° / - 265°	±180°/s	+85° / - 265°	±180°/s	+85° / - 265°	±180°/s	+85° / - 265°	±180°/s	+85° / - 265°	±180°/s	+85° / - 265°	±180°/s	+85° / - 265°	±180°/s	+85° / - 265°	±180°/s		
Wrist 2	±175°	±180°/s	0°~355°	±180°/s	±175°	±180°/s	±175°	±180°/s	±175°	±180°/s	±175°	±180°/s	±175°	±180°/s	±175°	±180°/s	±175°	±180°/s	±175°	±180°/s	±175°	±180°/s	±175°	±180°/s		
Wrist 3	±175° (Optional ±360°)	±180°/s	±175°	±180°/s	±360°	±180°/s	±360°	±180°/s	±175°(Optional ±360°)	±180°/s	±360°	±180°/s	±175°(Optional ±360°)	±180°/s	±175°(Optional ±360°)	±180°/s	±175°(Optional ±360°)	±180°/s	±175°(Optional ±360°)	±180°/s	±175°(Optional ±360°)	±180°/s	±175°(Optional ±360°)	±180°/s		
Typical TCP speed	1m/s				1m/s				1m/s		1m/s		2m/s		1.5m/s		1m/s		2m/s		2m/s		2m/s			
IP classification	IP54 (IP65 Optional)				IP54				IP54 (IP65 Optional)		IP54 (IP65 Optional)		IP54 (IP65 Optional)		IP54 (IP65 Optional)		IP54 (IP65 Optional)		IP54 (IP65 Optional)		IP54 (IP65 Optional)		IP54 (IP65 Optional)			
Noise	<65dB				<65dB				<65dB		<65dB		<65dB		<65dB		<65dB		<70dB		<70dB		<70dB			
Robot mounting	Any orientation				Any orientation				Any orientation		Any orientation		Any orientation		Any orientation		Any orientation		Any orientation		Any orientation		Any orientation		Any orientation	
I/O Ports	(DI) 2 (DO) 2	(DI) 2 (DO) 2	(DI) 2 (DO) 2	(DI) 2 (DO) 2	(DI) 2 (DO) 2	(DI) 2 (DO) 2	(DI) 2 (DO) 2	(DI) 2 (DO) 2	(DI) 2 (DO) 2	(DI) 2 (DO) 2	(DI) 2 (DO) 2	(DI) 2 (DO) 2	(DI) 2 (DO) 2	(DI) 2 (DO) 2	(DI) 2 (DO) 2	(DI) 2 (DO) 2	(DI) 2 (DO) 2	(DI) 2 (DO) 2	(DI) 2 (DO) 2	(DI) 2 (DO) 2	(DI) 2 (DO) 2	(DI) 2 (DO) 2	(DI) 2 (DO) 2	(DI) 2 (DO) 2		
	(AI) 1 (AO) 1	(AI) 1 (AO) 1	(AI) 1 (AO) 1	(AI) 1 (AO) 1	(AI) 1 (AO) 1	(AI) 1 (AO) 1	(AI) 1 (AO) 1	(AI) 1 (AO) 1	(AI) 1 (AO) 1	(AI) 1 (AO) 1	(AI) 1 (AO) 1	(AI) 1 (AO) 1	(AI) 1 (AO) 1	(AI) 1 (AO) 1	(AI) 1 (AO) 1	(AI) 1 (AO) 1	(AI) 1 (AO) 1	(AI) 1 (AO) 1	(AI) 1 (AO) 1	(AI) 1 (AO) 1	(AI) 1 (AO) 1	(AI) 1 (AO) 1	(AI) 1 (AO) 1	(AI) 1 (AO) 1		
Tool I/O power supply	24V/1.5A				24V/1.5A				24V/1.5A		24V/1.5A		24V/1.5A		24V/1.5A		24V/1.5A		24V/1.5A		24V/1.5A		24V/1.5A			
Footprint	128mm				125mm				128mm		128mm		149mm		190mm		190mm		190mm		240mm		240mm		240mm	
Weight	≈15kg				≈10kg				≈10.5kg		≈11.25kg		≈22kg		≤45kg		≈40kg		≈40kg		≈85 kg		≈85 kg		≈85 kg	
Operating temperature	0~45°C				0~45°C				0~45°C		0~45°C		0~45°C		-20~45°C		0~45°C		0~45°C		0~45°C		0~45°C		0~45°C	
Operating humidity	90%RH(non-condensing)				90%RH(non-condensing)				90%RH(non-condensing)		90%RH(non-condensing)		90%RH(non-condensing)		90%RH(non-condensing)		90%RH(non-condensing)		90%RH(non-condensing)		90%RH(non-condensing)		90%RH(non-condensing)		90%RH(non-condensing)	
Materials	Aluminium 、 Steel				Aluminium 、 Steel				Aluminium 、 Steel		Aluminium 、 Steel		Aluminium 、 Steel		Aluminium 、 Steel		Aluminium 、 Steel		Aluminium 、 Steel		Aluminium 、 Steel		Aluminium 、 Steel		Aluminium 、 Steel	
Black Optional	no				no				no		no		yes		no		yes		no		no		no		no	

■ Typical power test payload settings, different loads are set according to robot models, payload configuration parameters are as follows :

	FR3 payload setting: 3kg, Z-axis: 18mm	FR3-C payload setting: 3kg, Z-axis: 18mm	FR3-WMS payload setting: 3kg, Z-axis: 18mm	FR3-WML payload setting: 3kg, Z-axis: 18mm	FR5 payload setting: 5kg, Z-axis: 30mm	FR5-WML payload setting: 5kg, Z-axis: 30mm	FR10 payload setting: 10kg, Z-axis: 60	FR16 payload setting: 16kg, Z-axis: 96mm	FR20 payload setting: 20kg, Z-axis: 120mm	FR30 payload setting: 30kg, Z-axis: 200mm
Typical average power	220W	200W	90W	140W	260W	270W	300W	310W	620W	600W
Typical peak power	280W	230W	130W	240W	310W	620W	500W	410W	810W	910W

Select aging test program, connect robot's total power to power meter, set robot to automatic mode, set global speed to 100, click run, if there are no abnormalities after running two cycles, start continuous testing for 24 hours. After 24 hours, respectively, record the peak and average power of the power meter, and then statistically analyze each model :

CONTROLLER TECHNICAL SPECIFICATION



DC MINI Controller 2kW



DC Controller 5kW



AC MINI Controller 2kW



AC Controller 5kW

Features

IP classification	IP54	IP54	IP54	IP54
Operating temperature	0-45°C	0-45°C	0-45°C	0-45°C
Operating humidity	90%RH(non-condensing)	90%RH(non-condensing)	90%RH(non-condensing)	90%RH(non-condensing)
I/O Ports	(DI) 16 (DO) 16 (AI) 2 (AO) 2 High speed pulse input 2	(DI) 16 (DO) 16 (AI) 2 (AO) 2 High speed pulse input 2	(DI) 16 (DO) 16 (AI) 2 (AO) 2 High speed pulse input 2	(DI) 16 (DO) 16 (AI) 2 (AO) 2 High speed pulse input 2
I/O power supply	24V/1.5A	24V/1.5A	24V/1.5A	24V/1.5A
Standard communication	I/O、TCP/IP、Modbus_TCP/RTU	I/O、TCP/IP、Modbus_TCP/RTU	I/O、TCP/IP、Modbus_TCP/RTU	I/O、TCP/IP、Modbus_TCP/RTU
Optional communication	CC-Link IE Field Basic、Profinet、Ethernet/IP、EtherCAT	CC-Link IE Field Basic、Profinet、Ethernet/IP、EtherCAT	CC-Link IE Field Basic、Profinet、Ethernet/IP、EtherCAT	CC-Link IE Field Basic、Profinet、Ethernet/IP、EtherCAT
Communication Board Optional Configuration	MiniPCI Express - real-time Ethernet PC Board	MiniPCI Express - real-time Ethernet PC Board	MiniPCI Express - real-time Ethernet PC Board	MiniPCI Express - real-time Ethernet PC Board
Software development kit	C#/C++/Python/ROS/ROS2	C#/C++/Python/ROS/ROS2	C#/C++/Python/ROS/ROS2	C#/C++/Python/ROS/ROS2

Physical

L*W*H	245*180*44.5mm (No protrusions)	245*180*89 mm (No protrusions)	245*180*44.5mm (No protrusions)	245*180*89mm (No protrusions)
Weight	2.1kg (Weight without wire)	2.957kg (Weight without wire)	2.5kg (Weight without wire)	3.6kg (Weight without wire)
Materials	Galvanized plate	Galvanized plate	Galvanized plate	Galvanized plate
Power supply	30-60VDC	30-60VDC	100-240VAC / 10A / Single-phase / 50-60Hz	100-240VAC / 16A / Single-phase / 50-60Hz
Output power	48VDC / 42Amax	48VDC / 104Amax	48VDC / 42Amax	48VDC / 104Amax

Applicable Robot

FR3,FR3-WMS,FR3-WML,FR5,FR5-WML,FR10,FR16

FR20/FR30

FR3,FR3-WMS,FR3-WML,FR5,FR5-WML,FR10,FR16

FR20/FR30

SAFETY BOX



IP classification	IP54
Button function	Manual/Auto, Drag, Point Record, Match or Not with Safety Button Box, Start/Stop, Shutdown
Communication	TCP/IP
Network transfer rate	100M
Power over ethernet	Standard POE
L*W*H	136*60*66mm (No protrusions)
Weight	490g (Cable weight included)
Materials	ABS
Cable length	5m
Number of keys	≥20W

Human-robot interaction tools for basic interaction functions. It can be linked with computers, tablets and other devices through the RJ45 interface, and directly log in to the Web App teaching interface.

TEACH PENDANT [Optional]



IP classification	IP54
Operating humidity	90%RH(non-condensing)
Display resolution	1280 x 800 pixels
L*W*H	268*210*88mm
Weight	1.6kg
Materials	ABS、PP
Cable length	5m

The teach pendant, computer, tablet or mobile phone is connected to the WebAPP system to realize the operation of the collaborative robot.

EXPLOSION-PROOF CABINET [Optional]



Explosion-Proof Cabinets (Integral Explosion-Proof)



Robot (full range explosion-proof)

It has good technical performance. The cabinet must be resistant to vibration, impact, corrosion, dust, water, and radiation to ensure stable and reliable operation of devices. Good usability and safety protection facilities, easy operation, installation and maintenance, and to ensure the safety of the operator.

IP classification	IP65
Operating Environment Temperature	0°C-45°C
Minimum Positive Pressure	100pa
Maximum Positive Pressure	1000pa
Rated Input Voltage	100-240Vac
Maximum Leakage	15L/Min
L*W*H	682*500*1100(Includes alarm light 1286)
Weight	75kg
Materials	Carbon Steel + Stainless Steel
Cabinet Volume	126L
Ventilation Flow Rate	120L/min
Ventilation Time	14min
Protective Gas	AIR
Explosion-proof Cabinet Certificate	CE22.7131

DRAWINGS

Unit : mm

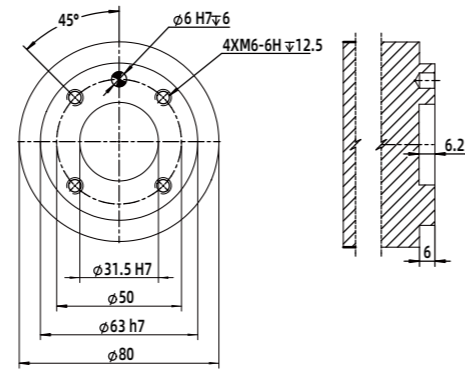

▶ ROBOT END-EFFECTOR
COMPATIBLE WITH
INDUSTRIAL ROBOT
END-EFFECTOR
CONNECTION METHODS

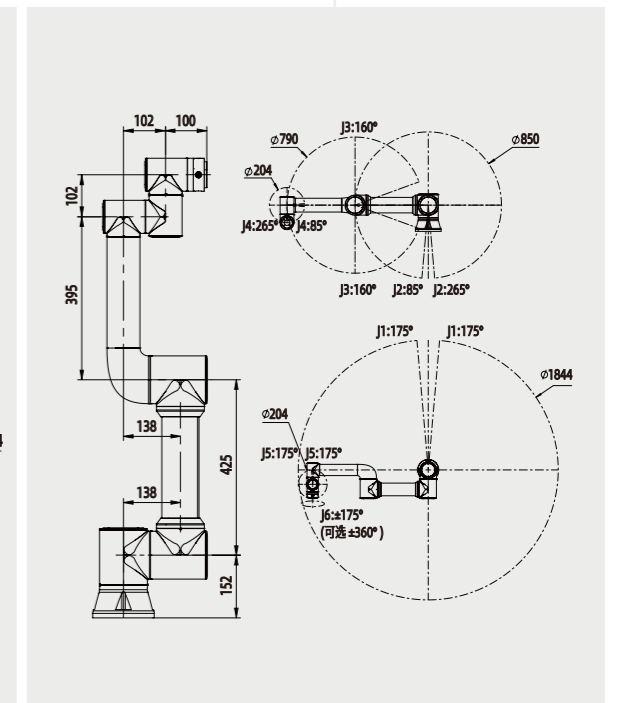
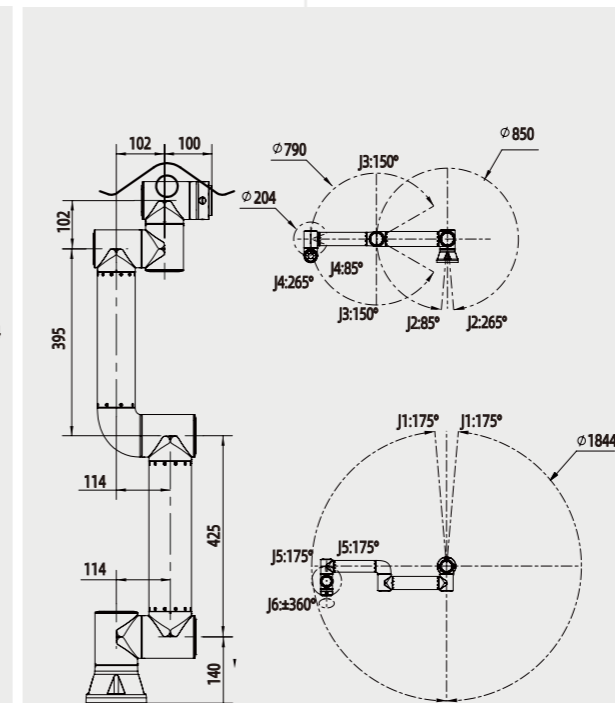
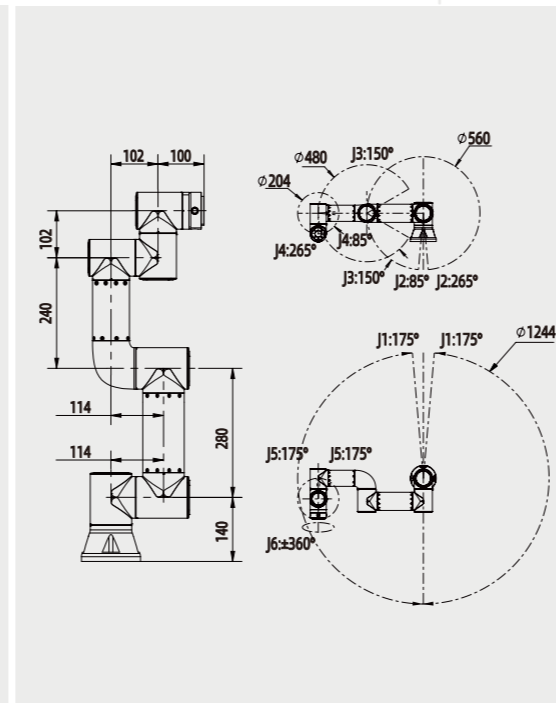
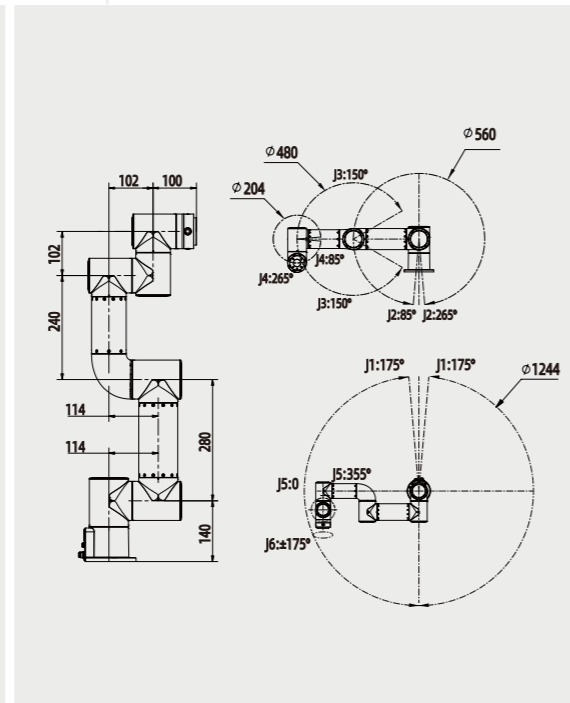
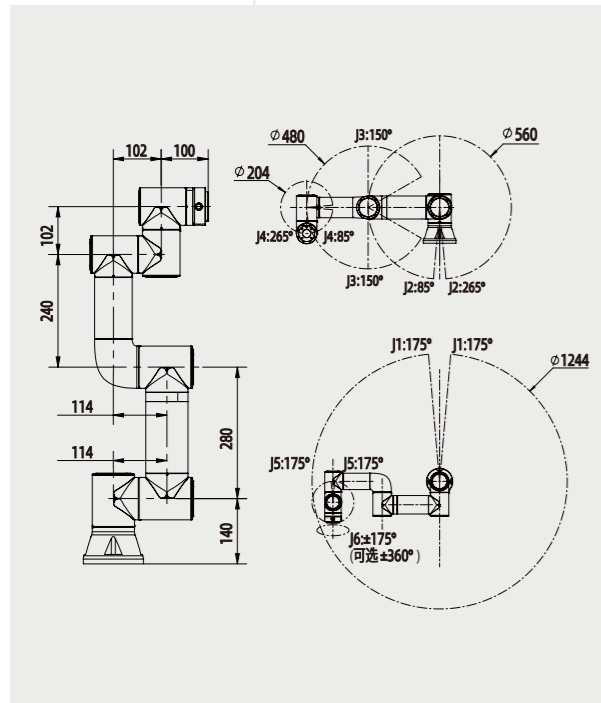

FR3

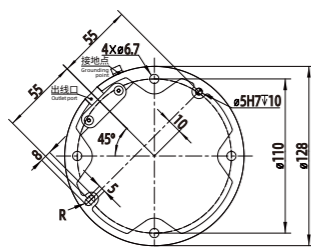

FR3 Pedestal diagram

FR3-C

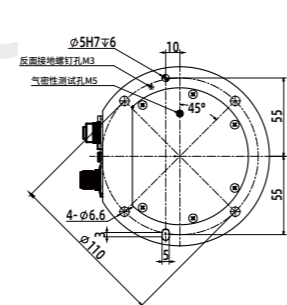

FR3-C Pedestal diagram

FR3-WMS

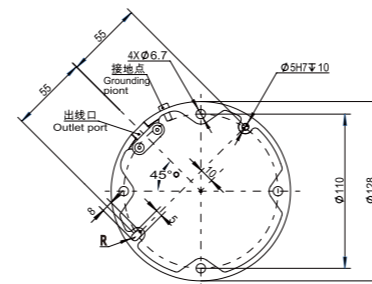

FR3-WMS Pedestal diagram

FR3-WML

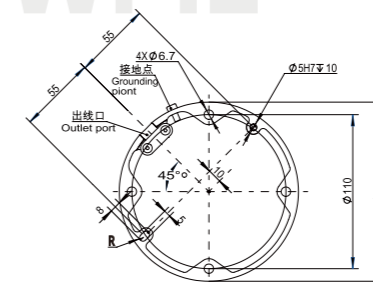

FR3-WML Pedestal diagram

FR5

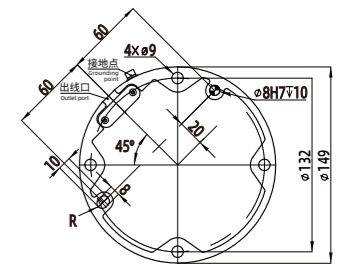

FR5 Pedestal diagram

DRAWINGS

Unit : mm

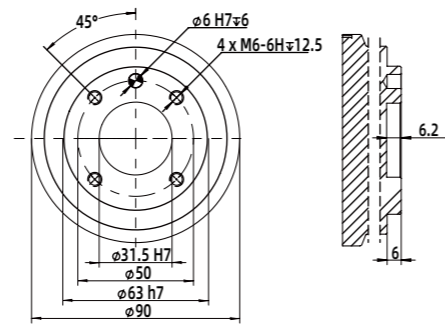

▶ ROBOT END-EFFECTOR COMPATIBLE WITH INDUSTRIAL ROBOT END-EFFECTOR CONNECTION METHODS

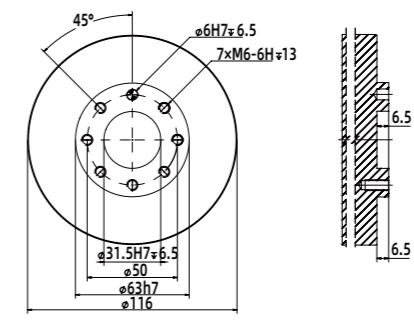

▶ COMPATIBILITY OF ROBOT END EFFECTOR CONNECTION METHODS OF THE END EFFECTOR OF INDUSTRIAL ROBOTS

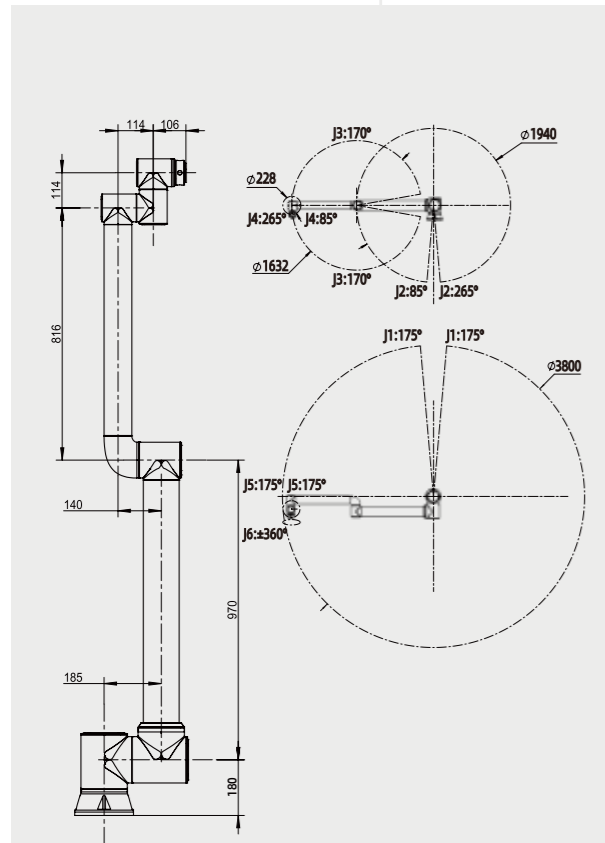

FR5-WML

FR5-WML Pedestal diagram

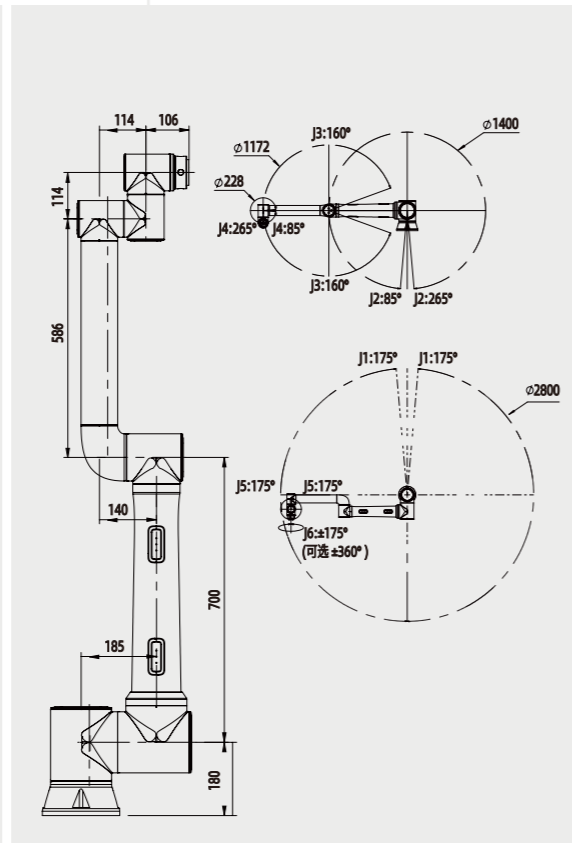
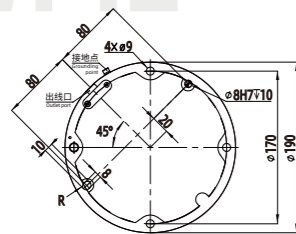

FR10

FR10 Pedestal diagram

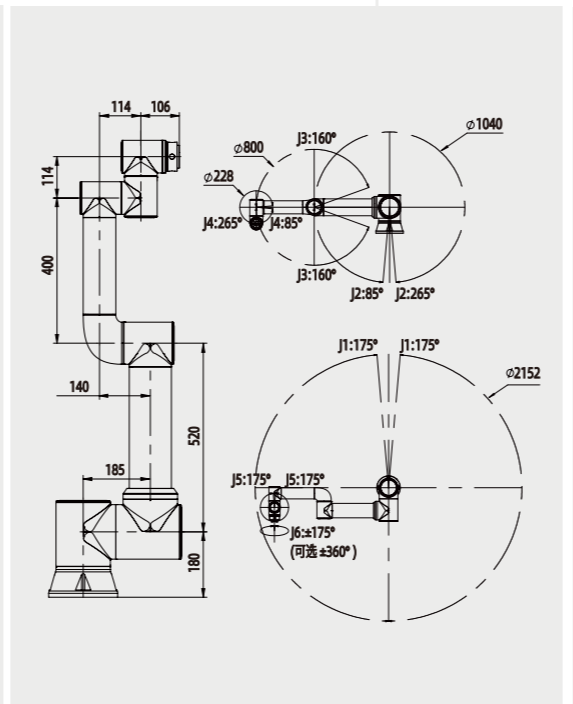
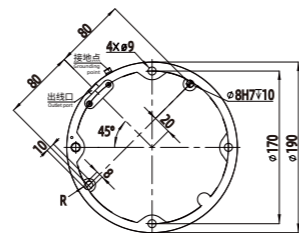

FR16

FR16 Pedestal diagram

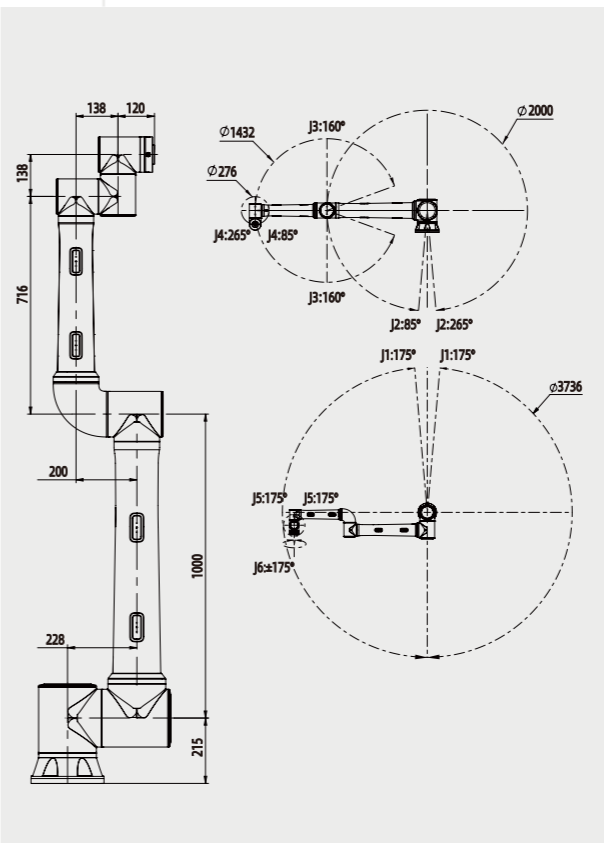
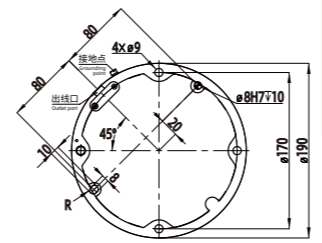

FR20

FR20 Pedestal diagram

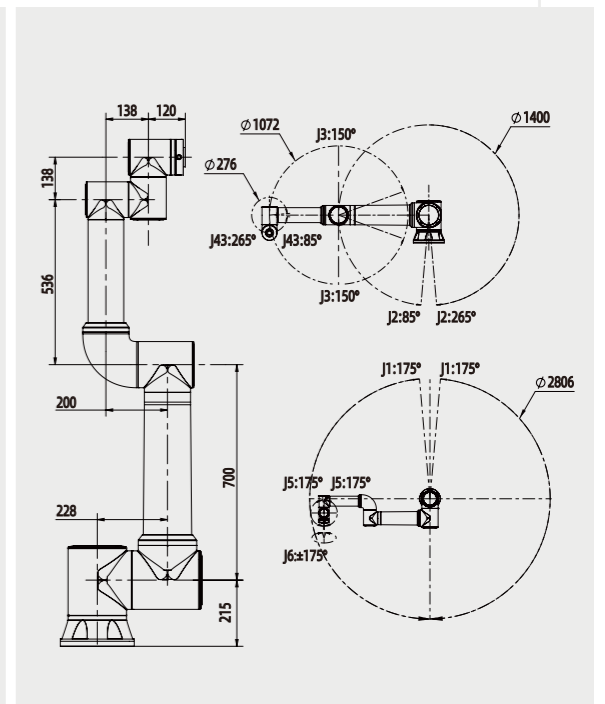
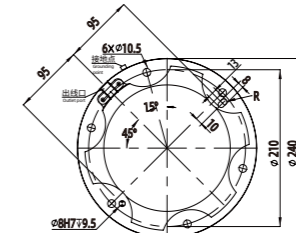

FR30

FR30 Pedestal diagram

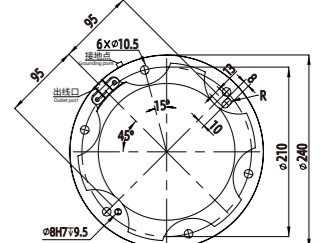



FR + ACCESSORIES ECOSYSTEM

* FAIRINO only provides required components and does not offer complete solution

One-Step Palletizing Workstation

Complete palletizing automation tasks in three steps

Just three steps are needed to complete the overall programming work for FAIRINO turnkey palletizing solution. The graphical programming is convenient and efficient; plug and play allows for quick and easy switching, achieving production line flexibility and automation.

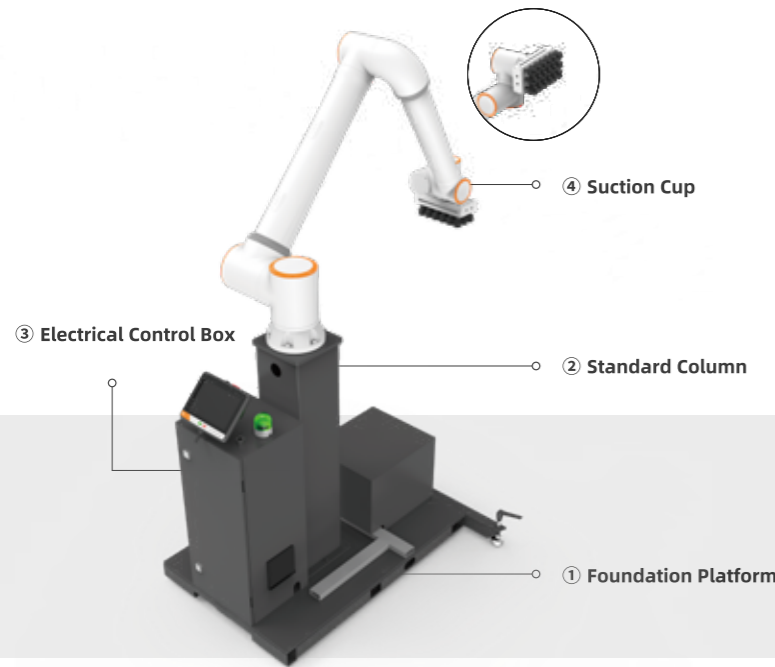

Palletizing Workstation Components

Using FR20

Column height: **1210mm**
 Pallet size: **1200*1100mm/1200*800mm**
 The workstation supports floor mobility.
 The fixed FR20 palletizing system weighs approximately **330 kg**.
 The column-mounted version of the palletizing kit supports a stacking height of up to **1800 mm**.

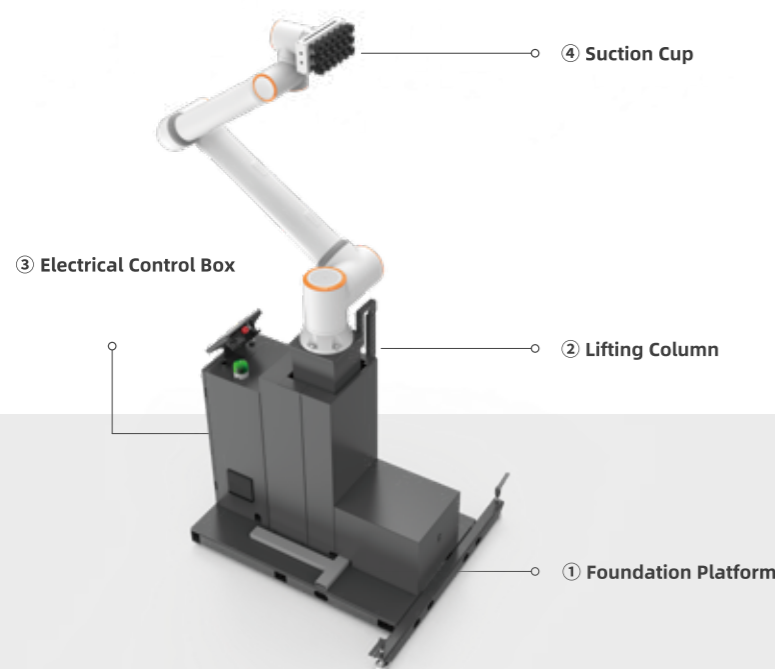

Using FR10

Lifting column height range: **1140-1640mm, lifting speed 50 mm/s**
 Electrical specification:
 Main Power Supply : **110-240 VAC**
 Pallet size: **1200*1100mm/1200*800mm**
 The workstation supports floor mobility.
 Total weight: Approx**375kg**

Using FR20

Lifting column height range: **1140-1640mm, lifting speed 50 mm/s**
 Electrical specification:
 Main Power Supply : **110-240 VAC**
 Pallet size: **1200*1100mm/1200*800mm**
 The workstation supports floor mobility.
 Total weight: Approx**410kg**

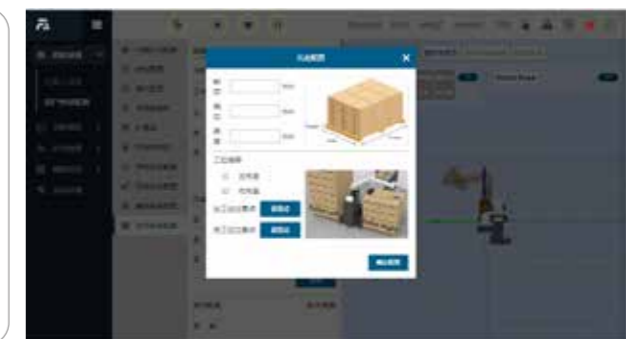
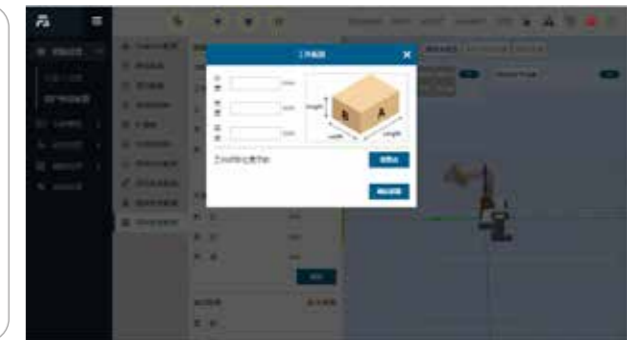
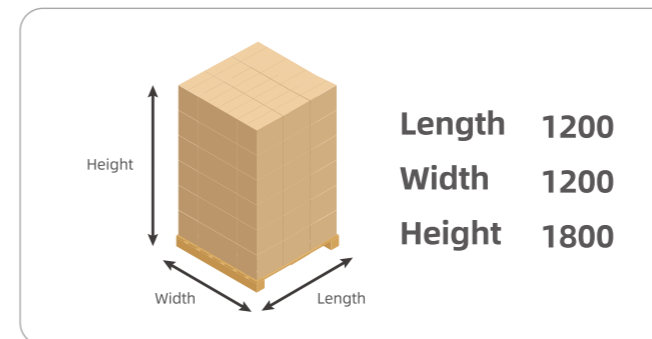
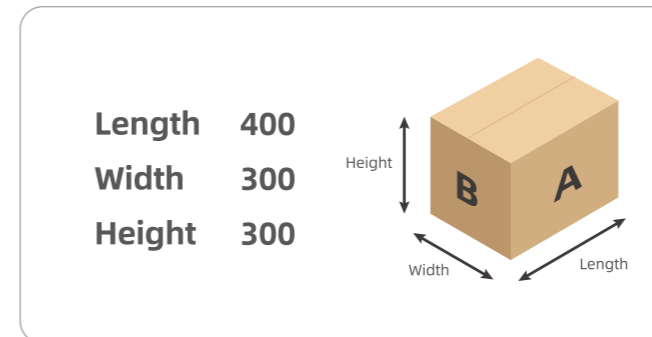

Web interface

Delivery Time 25 working days



Code to get the accessory list
 Including software & hardware accessories

Palletizing Solution

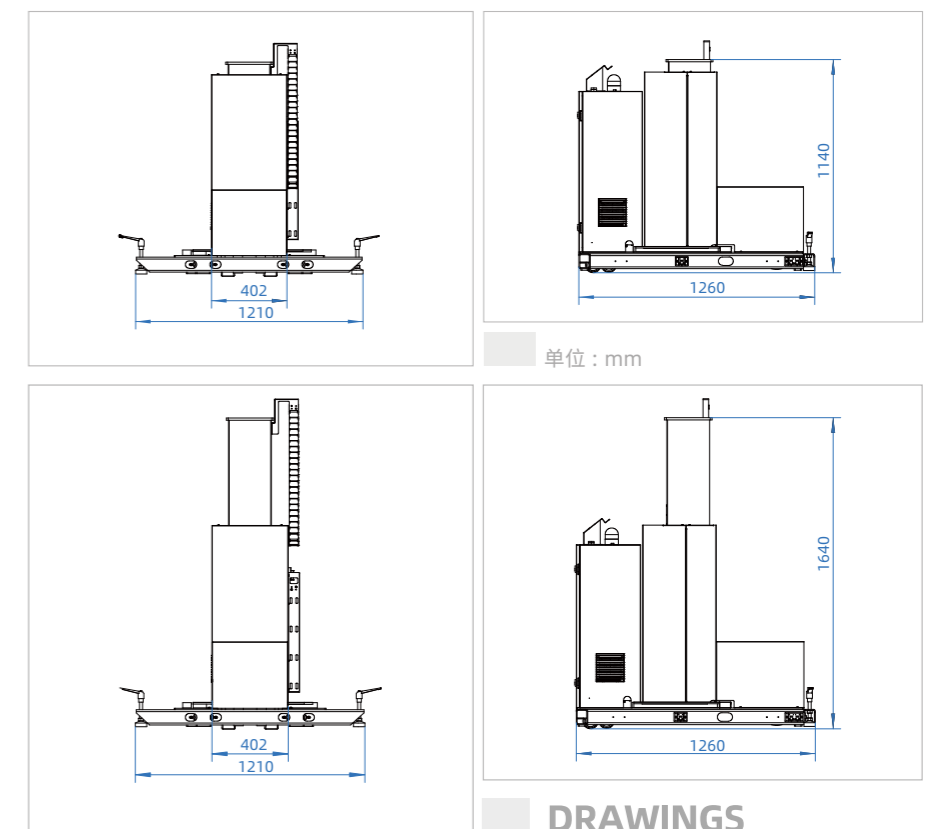

DRAWINGS

3D Vision-Based No-Programming Welding Solution

Open a new journey of convenient welding with one click

This solution integrates FAIRINO cobots, 3D cameras, and the FAIRINO AIRLab system. Paired with a no-programming welding platform, it enables automatic and precise weld seam detection, efficient teaching-free operation, and intelligent weld path analysis and planning – ensuring high consistency and accuracy in welding tasks.



FR-Welding-Hardware

Welding Hardware

Solution

- ① Welder (with water tank): Ehave2 CM500M
- ② 3D Camera: FRSV-Nano, FRSV-Nano-Pro, FRSV-Nano-Pro-C
- ③ Switch Cabinet
- ④ Magnet (3 pcs)
- ⑤ Trolley
- ⑥ Router: TL-CPE1300D
- ⑦ Controller
- ⑧ Torch Extension Cable
- ⑨ End tool

Technical Specification

Size **1472*840*1649mm**
 Magnetic base for fixation, can be easily moved around
 Magnetic base size **382*331*121mm**
 The equipment is fixed on a trolley, which can be moved along with the trolley
 The wire feeder can rotate 360° and can be detached from the trolley and placed freely

Robot Vision

Solution

- ① 3D Camera: FRSV-Nano, FRSV-Nano-Pro, FRSV-Nano-Pro-C
- ② IPC Industrial Processing Computer
- ③ IPC Graphics + Graphics Card Display Card : RTX A2000
- ④ Vision Software

Technical Specification

Field of View : 52°*50° (H*V)
 Near Field: 329*287mm@350mm
 Far Field: 1021*881mm@1100mm
 Working Range: 350 ~1100mm (varies with environment)
 Point Cloud Resolution: 1280 x 1024
 Accuracy: <0.05%@1100mm

Delivery Time 25 working days

Qualification Magnet: GIG
 IPC Graphics + Graphics Card Display Card: CE、UL、RHOS



Code to get the accessory list including software & hardware accessories

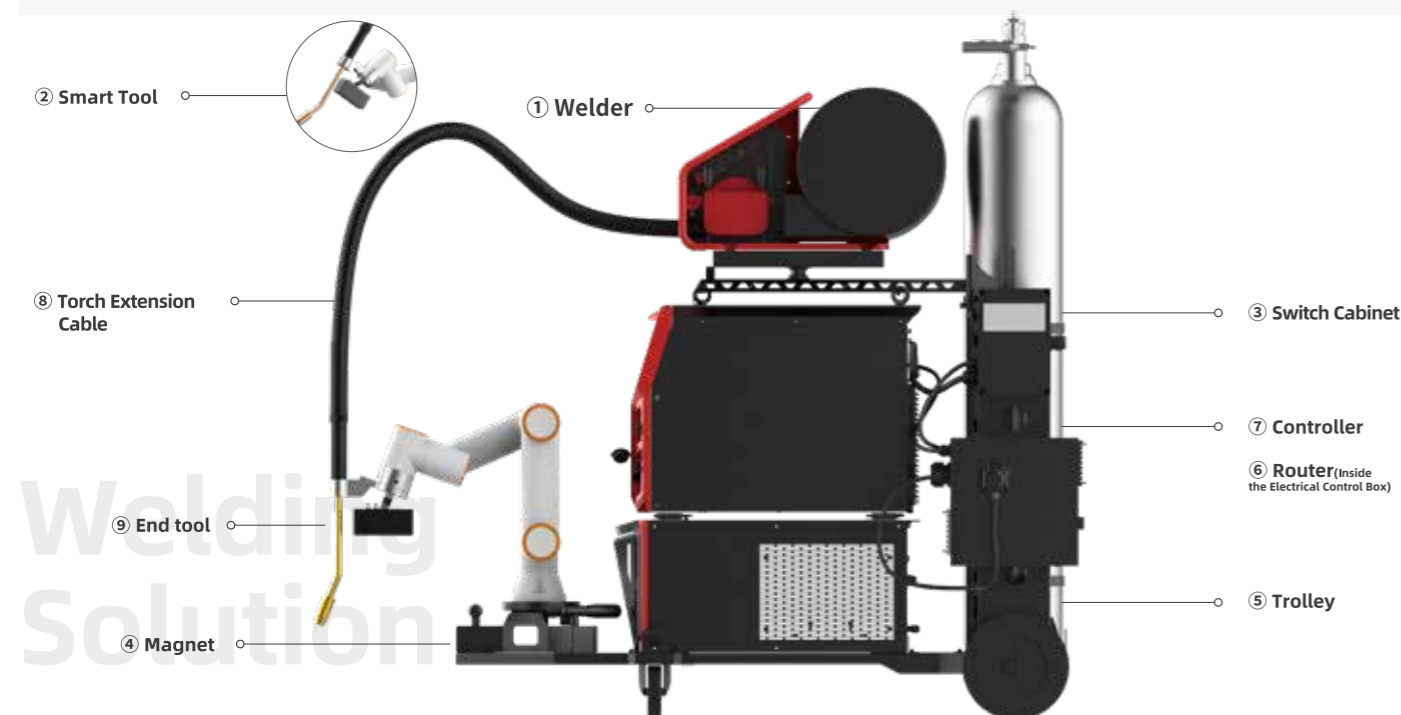

Welding Solution

Unit : mm
DRAWINGS

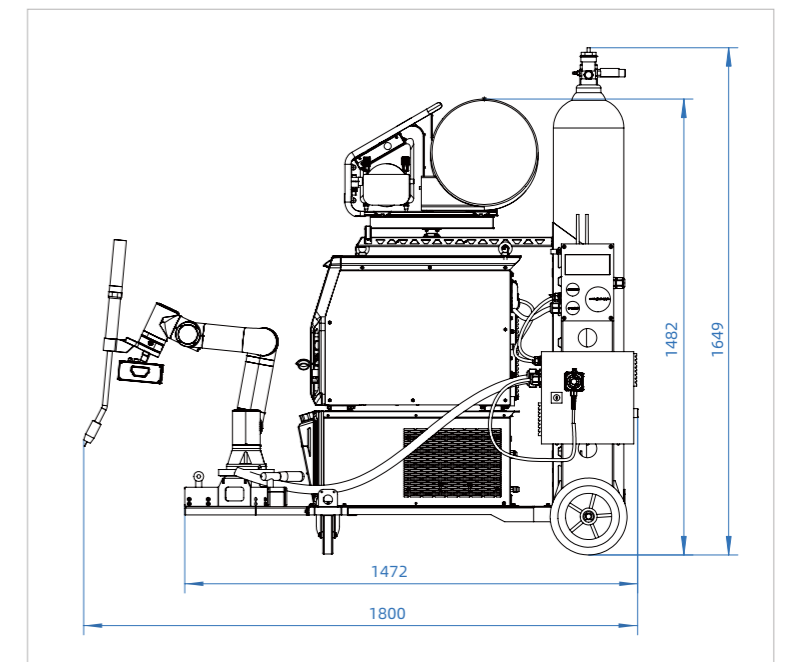
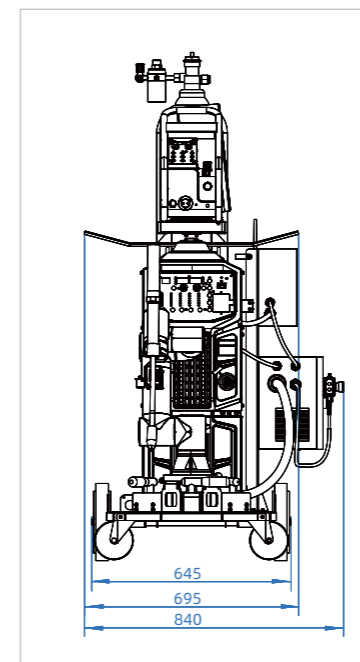

CNC Workstation

Robotic Ecosystem Application in the CNC Industry

Powered by FAIRINO 6-axis collaborative robots, this solution offers easy programming, fast deployment, and high safety. It accelerates CNC automation upgrades, enabling flexible production capacity and helping manufacturers quickly adapt to diverse and changing product demands.



CNC Workstation Components

Main Components

- ① Drawer shelf
- ② Workstation main body
- ③ FR10 robot
- ④ 45-degree mounting adapter
- ⑤ Robot mounting base
- ⑥ Teach pendant
- ⑦ Controller box access port

Technical Specification

Workstation dimensions **1100mm*790mm*1010mm**
 Fixed table dimensions **1100mm* W600mm**
 Weight **280kg** (excluding robot)
 Power specifications **110-220VAC**
 Operation methods **Web-based teach pendant**

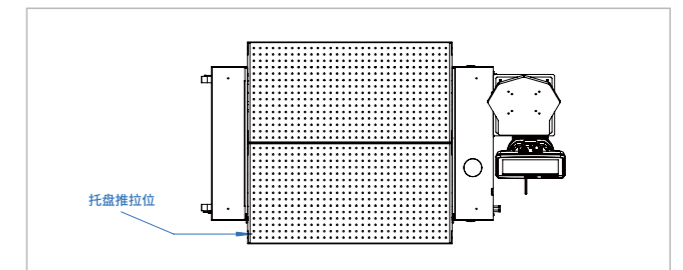
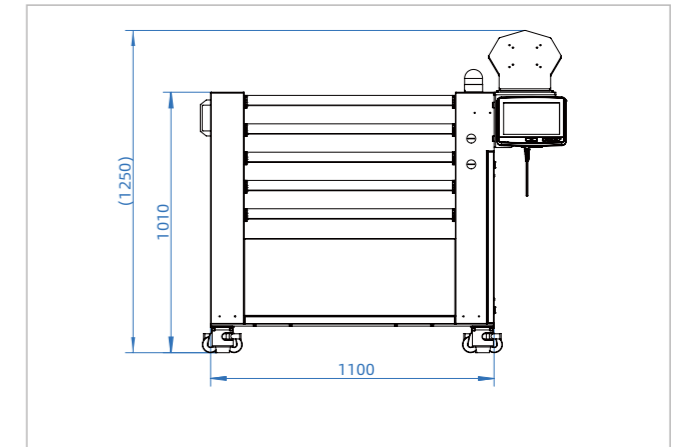
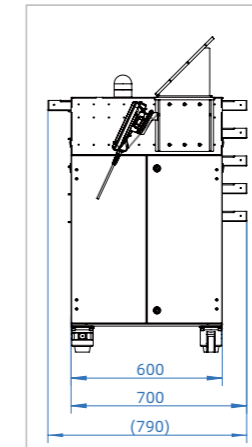

Unit : mm
DRAWINGS

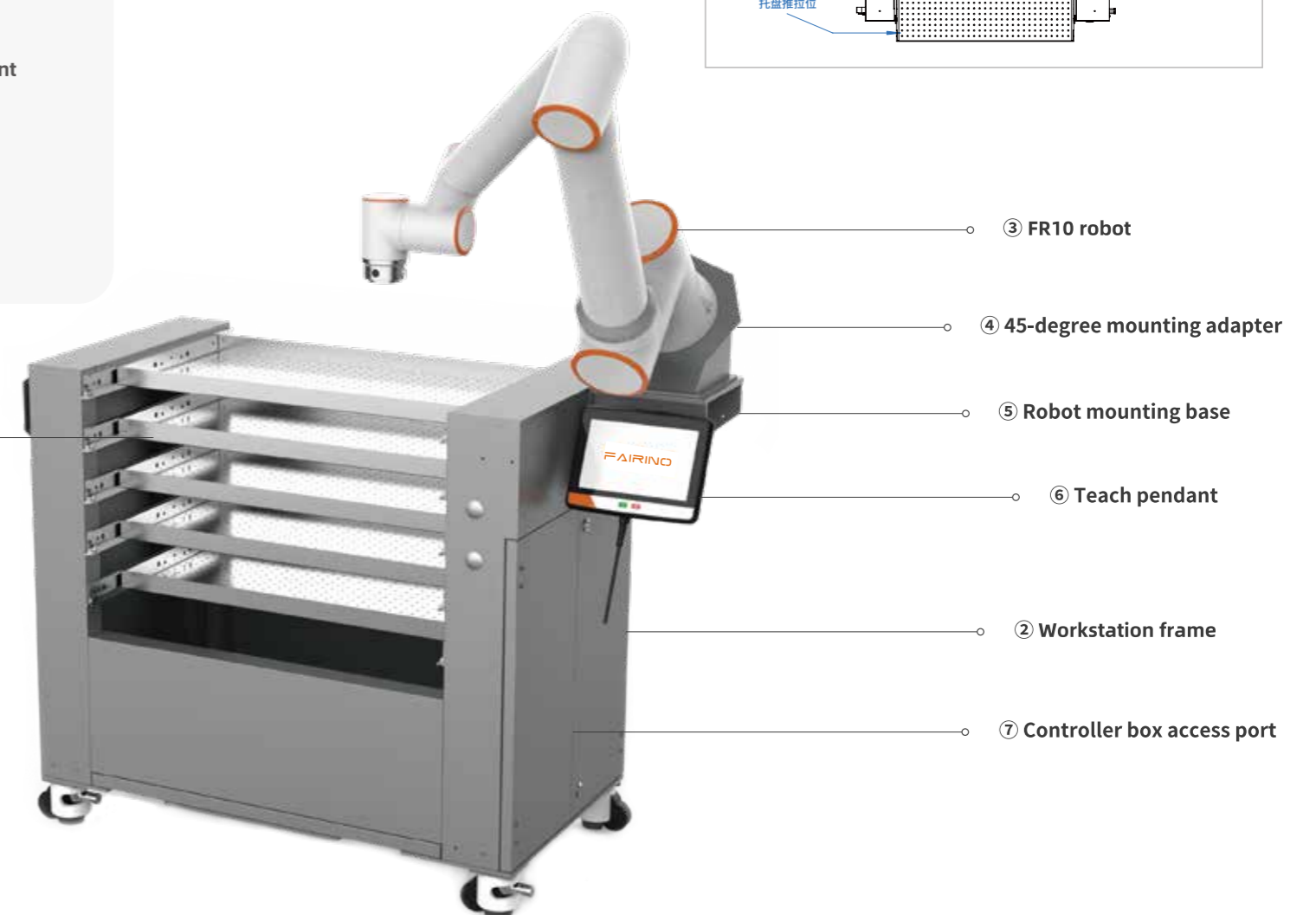

Delivery Time 25 working days

CNC WORKSTATION

Spark Project Education Platform

Eco-level application of "Robot + N" in education field

By integrating visual systems, end effectors, torque sensors, mobile platforms, and other hardware and software components with robots, we achieve a "hand" + "eye" + "foot" + "brain" hardware combination, making our platform more open, user-friendly, and with greater expandability.



Plug and play



Compatible with peripheral devices



Support secondary development

Integrated Modular Design

Open Hardware and Software Platform

Secure Innovative Application



FR-Spark Project-Hardware

■ Gripper ■ Camera ■ Sensor

EDUCATIONAL WORKBENCH

Gripper	Model: EPG40-050	Adjustable Stroke Single Finger Grip Force	0-40mm 2-50N	Body Weight Communication Protocols	360g Modbus RTU(RS 485), Digital I/O
Camera	Model: Gemini 2	Depth Image Measurement Range Working Range Operating Temperature	0.15m-10m 0.2m-5m 0 ~ 40°C	SDK Depth Image Resolution @ Frame Rate * 3	Orbbec SDK 1280x800@30fps 640x400@60fps
Sensor	Model: FR-6F-75MM	Resolution Overall Accuracy Overload Capacity	0.1%FS ≤1%FS 200%	Repeatability Zero Drift (Temperature Coefficient) Operating Temperature	0.2%FS 0.3%FS/10°C -20~80°C
Delivery Time	25 working days				
Qualification	Gripper: CE , RoHS				



*The parameters provided are for reference only. Actual accuracy may vary depending on the selected product configuration

Code to get the accessory list including software & hardware accessories



Item	Gemini 2	EPG40-050	FRMG2	RG75-300	FRSV-Nano / FRSV-Nano-Pro / FRSV-Nano-Pro-C	FR-6F-75MM
Performance Parameters	Depth Image Measurement Range: 0.15m-10m Working Range: 0.2m-5m Camera Driver: UVC SDK: Orbbec SDK Operating Temperature: 0~40°C Depth Image Resolution @ Frame Rate * 3: 1280x800@30fps, 640x400@60fps Color Image Resolution @ Frame Rate * 4: 1920x1080@30fps, 1280x720@60fps	Adjustable Stroke: 0-40 mm Single Finger Grip Force: 2-50 N Repeatability: ±0.02 mm Opening/Closing Time: 0.5 s Maximum Recommended Load: 0.8 Kg Operating Environment: 5~40°C, Below 85% RH	Adjustable Stroke: 0-50 mm Single Finger Grip Force: 150 N Repeatability: ±0.03 mm Opening/Closing Time: 0.4 s Maximum Recommended Load: 3 Kg Operating Environment: 5~40°C, Below 85% RH	Adjustable Stroke: 0-75 mm Single Finger Grip Force: 40-300 N Repeatability: ±0.02 mm Opening/Closing Time: 0.55 s Maximum Recommended Load: 6 Kg Operating Environment: 5~40°C, Below 85% RH	Field of View (FOV): 52°*50° (H*V) Near Field: 329*287mm@350mm Far Field: 1021*881mm@1100mm Working Range: 350~1100mm (varies with environment) Point Cloud Resolution: 1280 x 1024 Accuracy: <0.05%@1100mm Point Cloud Frame Rate: <3 Hz Power Supply: POE (Power over Ethernet)	Fx,Fy: 100N Fz: 200N Mx,My: 5Nm Mz: 5Nm Resolution: 0.1%FS Repeatability: 0.2%FS Overall Accuracy: ≤1%FS Zero Drift (Temperature Coefficient): 0.3%FS/10°C
Dimension	90 * 25 * 30 mm ± 0.5mm	40*24*87mm	96*64*40mm(Without Fingers)	131.5*100*75mm	FRSV-Nano: 136.5 * 60.5 * 45.1mm(without camera cover) FRSV-Nano-Pro: 139 * 61.5 * 46mm(without camera cover) FRSV-Nano-Pro-C: 139 x 63.8 x 58mm(with camera cover)	75*30.5mm
Weight	97g	360g	800g	1.5kg	482g(without camera cover)	0.2kg
IP Classification	/	IP40	IP54	IP65	IP65	IP64
Communication Interface	MIPI	Modbus RTU(RS 485), Digital I/O	RS 485	Modbus RTU(RS 485)	GigE	RS485/Industrial Ethernet
Qualification	Class1, RoHS, FCC, CE, Reach, KC	CE, RoHS	/	CE, RoHS	/	/



COMPANY PROFILE

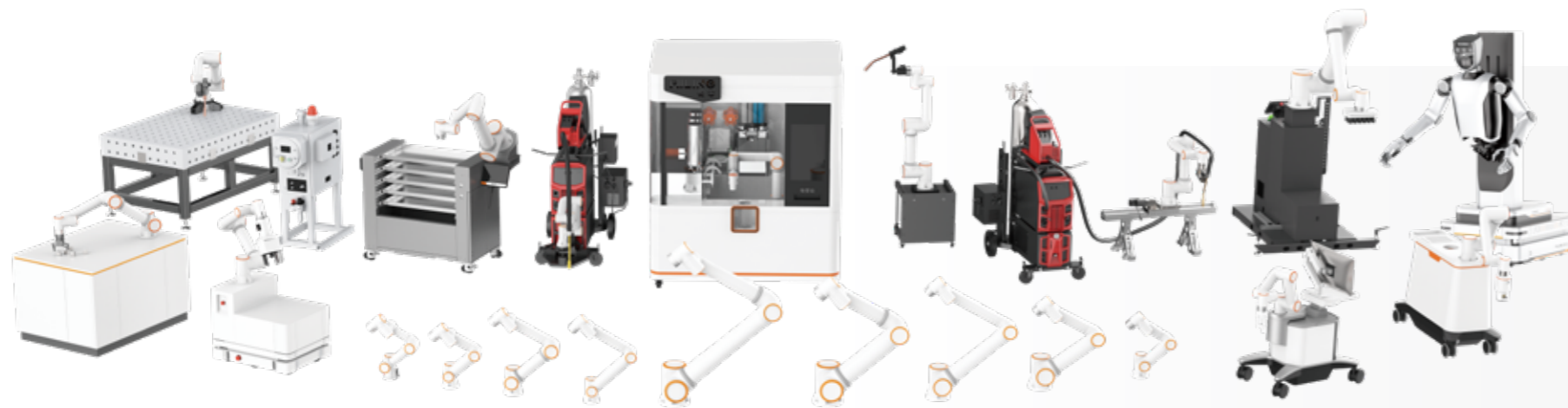

FAIRINO ROBOT

FAIRINO is the collaborative robot company who has achieved independent R&D of all core components.

We focus on user experience and leverage our tiered product portfolio, integrating cutting-edge technologies such as AI, vision, and sensing, to deliver highly convenient and deeply intelligent systems across industries. Our mission is to drive the widespread adoption of collaborative robotics from industrial to commercial applications, making advanced automation accessible to all.

We provide customized components, complete machines and systems for industry customers, the open development platform provides more convenience and possibility for our partners.

FAIRINO remains committed to the philosophy of advancing together with partners and customers, continuously delivering extraordinary value to them.

FAIRINO invites you to explore together and open up a diverse intelligent world.

In the era of intelligent manufacturing, how can collaborative robots redefine value?

Business Efficiency: Reduce costs, enhance quality, empower skill upgrading, and drive lean manufacturing.

Commercial Upgrade: Optimize service experiences, meet customer needs precisely, and build differentiated competitiveness.

Craft Heritage: Standardize artisanal processes, balance efficiency and quality, and revitalize traditional craftsmanship.

Life Companion: Intelligently handle household chores, customize cleaning and cooking solutions, and infuse technology into daily life.

From industrial manufacturing to commercial services, from artisan workshops to smart homes, FAIRINO Robotics continues to expand the boundaries of application, making future scenarios tangible today.